

# PLATINUM LINE

## PLATINUM LINE - SEVERE SERVICE CEILING FAN DIMENSIONS

### DIMENSIONS

Feature	190A-7S	190A-18S
Safety Cable	N/A	N/A
Cord/ Lead Wire	16"	16"
Top Canopy	4 3/8"	4 3/8"
Top to Bottom Length	19"	27"
Downrod Length (4)	7"	18"
Downrod Diameter	1"	1"
Bottom Canopy	4 3/8"	4 3/8"
Depth of Motor Housing	3 1/2"	3 1/2"
Width of Motor Housing	8"	8"
Blade Length (3) (4) (5)	26"	26"
Diameter/ Sweep	60"	60"

### SPECIFICATIONS

CFM	43,500	43,500
Area (sq. ft.)	2,400	2,400
Velocity (ft./m)	740	740
Volts	120	120
Amps	0.71	0.71
Watts	80	80
RPM	330	330
Weight (lbs.)	24.5	24.5

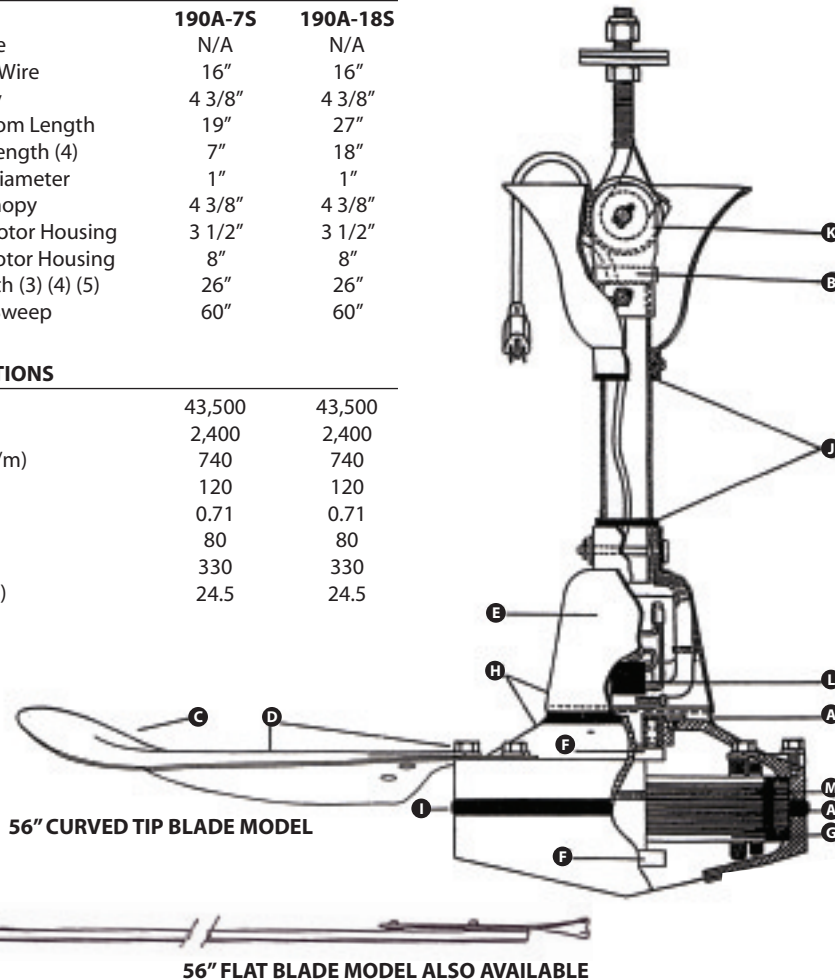

56" CURVED TIP BLADE MODEL

56" FLAT BLADE MODEL ALSO AVAILABLE

### FEATURES

Cords/ Lead Wires/ Safety Cables measured from top of down rod.

Model numbers 190A-7, 190A-18, 160F7, 60F7, FP56, FP56-36, FP36 feature plug and cord. All other models have **4 wire** leads.

**Model 160C, FP56C and FP48R feature straight blades. All other models have curved tipped blades.**

Model 190A also available with 56" diameter straight or curved tipped blades.

Blade bracket included in measured length.

Model 190, 160 and 136F fans use E961 36" downrod extension. Extending downrod on 190A will void downrod moisture seal

60F and FP series use E962 36" downrod extension.

Note: All fans with plug and cord require 60" plug and cord Part" Cord-WH to install 36" standard downrod.

Parts and installation charge apply if factory installed.

Customized downrod lengths over 36" available. Also 16' cord with plug part # Cord-Wh16

Heavy cast yoke for infield downrod change

High heat bearings -30°C to 175°C

**BANVIL 2000**

INDUSTRIAL CEILING FANS

Division of 3383768 Canada Limited

P.O. Box 23087, 55 Ontario Street, South Milton, Ontario L9T 2M3  
PH: 1.888.8BANVIL (22-6845) FX: 1.888.4BANVIL (22-6845)

## 5 YEAR WARRANTY

### PLATINUM 190A-7S & 190A-18S

- A Neoprene deflection boot helps keep out moisture and dust.
- B Pre-wired with 16" cord and built-in strain relief.
- C Aerodynamically designed curved-tip 60" blades for maximum air delivery
- D Precision-balanced lightweight aluminum blades for smooth, quiet operation.
- E All metal. No plastic.
- F Permanent, rubber-sealed ball bearings.
- G Totally enclosed .9 amp heavy duty motor with impedance protection.
- H Corrosion-resistant epoxy prime and finish coat on all metal housings and blades.
- I Neoprene sealed motor case
- J Heavy-duty neoprene seals
- K Simple J-hook mount
- L 9.5 mfd non-polar, weatherproof encapsulated, extra heavy-duty capacitor
- M High grade silicone steel motor laminations for maximum energy efficiency
- N Sealed downrod for complete motor moisture protection
- O Full five-year warranty.
- P Solid state infinite speed controls
- Q Uses less energy than a 100W bulb.
- R 7" or 18" downrod. 36" available.
- S Shipped completely assembled, except blades.



North America's Leading  
Manufacturer of Quality  
Industrial and Commercial  
Ceiling Fans

