



320W

UL/cUL Listed LED Flood Light



Applications:

Outdoor flood lighting, Building decoration lighting, Industrial lighting, Advertising lighting and Road lighting

Item Code: FLA320-DLC	Parameter Range
Power	320W(Meanwell)
LED Quantity	168PCS CREE LEDs
Color	Cool White
CCT	5700K
CRI	≥75
Life-Span	≥50,000 Hours
Flux	32000 +/- 200LM
Beam Angle	60°/ 120°
LED Manufacturer	CREE
Material	Aluminum + Toughened glass
Net Weight	MAX 12.8KG/PC
Gross Weight	MAX 13.5KG/PC
Inner Box Dimension	81.5*34*26CM
Outer Carton Dimension	84*35.5*28.5CM
Package Spec.	1PC/CTN,16KG/CTN



Distributed by:

320W

UL/cUL Listed LED Flood Light



Features:

- ✓ High efficiency and energy saving of more than 80%
- ✓ Ultra-high brightness
- ✓ High color-rendering index
- ✓ Long life $\geq 50,000$ hours

Technical Request:

Item	Units	Parameter range
Working Environment	$^{\circ}\text{C}$	$-37^{\circ}\text{C} - 55^{\circ}\text{C}$
Working Humidity		$\leq 95\%$
Storage Condition	$^{\circ}\text{C}$	$-40^{\circ}\text{C} \sim 80^{\circ}\text{C}$
Limited Voltage	V	100-277VAC 50/60Hz
Input Current	A	1.15-3.2
Protection Level		IP65(outdoor using)

Dimension:

FLA320-DLC



Dimension (mm)

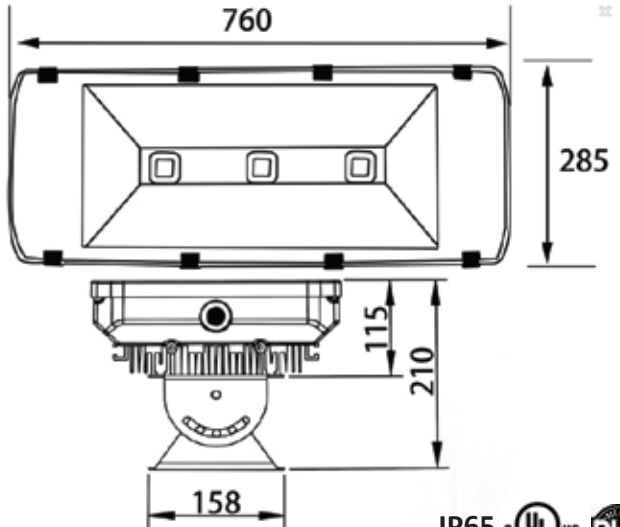

IP65 c 